

**AUTOCASE® SC-2**  
**SEMI-AUTOMATIC CASEMAKER**

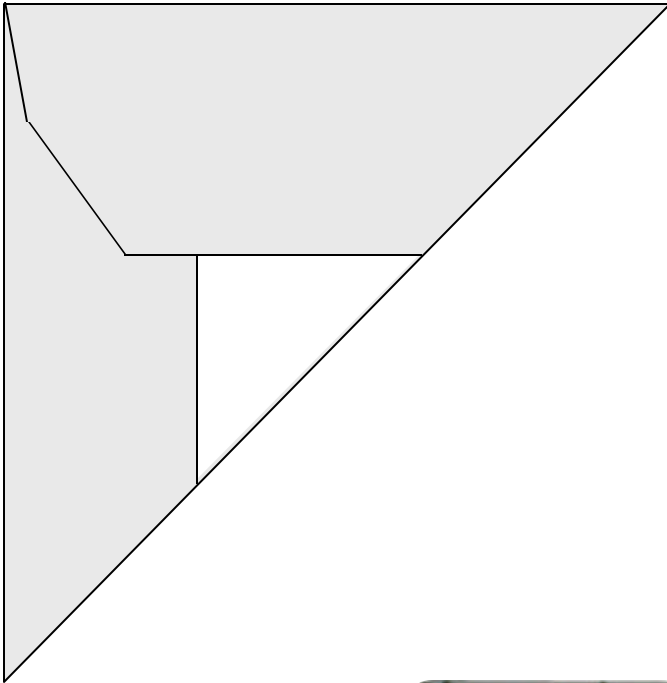

**ZERO SIZE CHANGE + ZERO SCRAP + QUICK TURNAROUND +  
SIMPLE OPERATION = PROFIT ON SHORT RUNS**

**SIMPLE**

With zero size change the Autocase does not require highly skilled operators or maintenance personnel.

**RELIABLE**

Our proven technology allows our customers to plan their production, day in and day out.

**VERSATILE**

Our customers produce virtually every turned edge product type using all types of cover material, boards and adhesives in run counts from one cover to five hundred or more.

**AFFORDABLE**

The SC-2 Autocase offers superior payback compared to alternative methods of automation or manual production based on cost to purchase, labor savings, zero scrap and reliable production output.



The SC-2 Autocase is well suited for running all types of case-made or turned-edge products. Our customers produce book covers, ring binders, menu covers, photo albums and more! A touch of a button switches between Standard (Edition) and Library Corners styles.

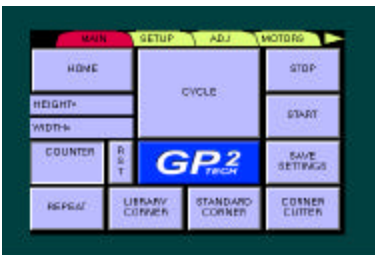

The Operator Interface Touchscreen is representative of the advanced technology built into the Autocase and not found on other entry or mid level bindery equipment.

The Touchscreen further exemplifies our commitment to "user" friendly, simple to operate casemakers.

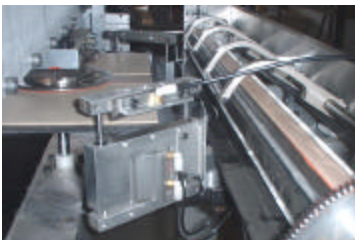

The Corner Trimmer Option automatically trims the Corners from the cover material very accurately during the casemaking operation. This feature streamlines production for On-Demand and Ultra Short Run applications while providing high quality, uniform corners on every cover—even in runs of one!

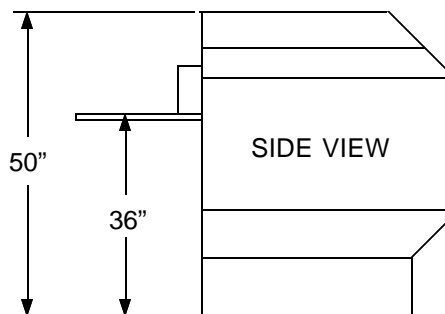
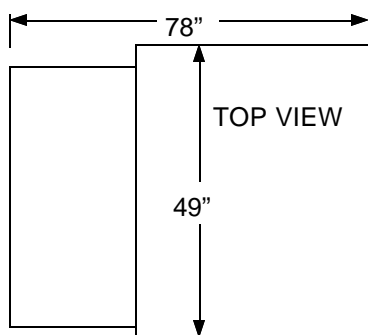

**AUTOCASE® SC-2**  
**Semi Automatic Casemaker**

**Specifications**

**Operating Speed:**

*Up to 300 cycles / hour*

**Make ready time:**

*Zero*

**Operators:**

*One*

**Operator Interface:**

*Touchscreen*

**Case Gage:**

*Built in*

**Case Size:**

*6.62" - 16" Height*

*8.62" - 26" Width\**

*\*28" Without Corner Trimmer*

**Board Thickness:**

*.060" - .125"*

*Padded board  
option available*

**Spine Thickness:**

*up to board thickness*

**Spine Width:**

*.25" - 3.25"*

**Electrical:**

*230 V, Single phase*

*50/60 Hz, 15 Amp*

**Compressed Air:**

*2cfm @ 80 psi*

**Machine weight:**

*Approx. 750 lbs*

*Specifications are subject to change or revision*

**Optional Equipment:**

*Automatic Corner Cutters*

*Outfeed Conveyor / Video*

*Assisted Registration System*

*GP<sup>2</sup> Technologies, Inc.  
3 Tallwood Drive, Unit 2  
Bow, NH 03304*

*Sales Tel. 1-800-435-4975*

*Sales Fax 1-802-888-4536*

*Tel. 603-226-0336*

*Fax 603-226-0444*

*Web: [www.gp2tech.com](http://www.gp2tech.com)*

*e-mail: [sales@gp2tech.com](mailto:sales@gp2tech.com)*